

AFCO Installation & Operation Instructions

Model #AF 944186 • Portable 60 Gallon Freedom XV Foamer

REQUIREMENTS

Ready-to-Use Chemical Solution

Compressed Air	14 CFM
Minimum Air Supply Line	3/8"
Hose	1" x 40'
Nozzle	00400

OPTIONS

Proportioning / Filling Options

1-Way Ball Valve Mixing Station (4 GPM)	# 985100
1-Way Push Lever Mixing Station (4 GPM)	# 981100
High Volume Mixing Station (9.9 GPM)	# 985835

Drain Foamer Attachment

Drain Foamer Attachment (XV & HV)	# 538250
-----------------------------------	----------

Air Pump Diaphragm Options - Santoprene Standard

Teflon Diaphragm Upgrade For 1/2" Air Pump	# 710919
--	----------



WEIGHT & DIMENSIONS

Shipping Weight: 176 lbs.

Shipping Dimensions: 50" x 40" x 44"

Ships On A Pallet



<http://www.afcocare.com>

**READ ALL
INSTRUCTIONS BEFORE
USING EQUIPMENT!**

Overview

The Portable 60 Gallon Freedom XV Foamer is a high-volume foam applicator for projecting foaming chemicals on to any surface up close or at distances up to 25 feet. This unit features an all stainless steel cart assembly and uses a rugged 1/2" Sandpiper air-operated, double-diaphragm pump to draw ready-to-use chemical from the tank. It injects compressed air into the solution to greatly increase volume and coverage ability and projects rich, clinging foam through the hose, wand and nozzle. Provides 15 minutes of foaming time per fill.

AFCO • 5000 Letterkenny Rd • Chambersburg, PA. 17201 • 1-800-345-1329



Safety & Operational Precautions

- For proper performance do NOT modify, substitute nozzle, hose diameter or length
- Manufacturer assumes no liability for the use or misuse of this unit.
- Wear protective clothing, gloves and eye-wear when working with chemicals.
- Always direct the discharge away from people and electrical devices.
- Follow the chemical manufacturer's safe handling instructions.
- DO NOT use d-Limonene or other chemicals that are not compatible with the Santoprene diaphragms.
- TEFLON upgrade is available.

TO INSTALL (REFER TO DIAGRAM, NEXT PAGE.)

1. Fill the tank with ready to use solution to the desired level. Replace lid.
2. Attach a compressed airline to the inlet ball valve. DO NOT TURN ON

TO OPERATE

- **Always make sure the discharge ball valve is closed or pointed in a safe direction before turning the air on. Ball valve can be shut off at any time during operation but should not be left unattended for long periods of time. Expect a strong blast when re-opening ball valve.**
 - **The unit has been tested and is ready to operate, the pump air pressure preset at 60 PSI. This is the optimum pressure. The foam consistency regulator is preset at 50. Test "as is" before making any adjustments. Pump pressure can be raised to 90 PSI for extra volume or increased throw distance.**
 - The foam consistency air regulator is preset at 50 PSI. To adjust foam consistency, turn the foam consistency regulator clockwise for dryer foam and counterclockwise for wetter foam. Wait several seconds after each adjustment to see the results. Keep this pressure below the pump pressure.
1. With the foam wand in hand direct the discharge in a safe direction and open the discharge ball valve and the air ball valve.
 2. If the flow of foam surges, the foam consistency air regulator pressure is too high or the chemical concentration is too weak, reduce the air pressure by turning the knob counterclockwise until the foam flow stabilizes. Or add more chemical concentrate.
 3. A medium-wet foam will give the best cleaning results! Very dry foam will NOT clean as well!
 4. When foaming is complete:
 - Close the discharge ball valve.
 - Promptly return to the unit and close the air ball valve.
 - Briefly re-open the discharge ball valve to relieve pressure in the hose.
 5. Rinse the work surface before the foam dries.

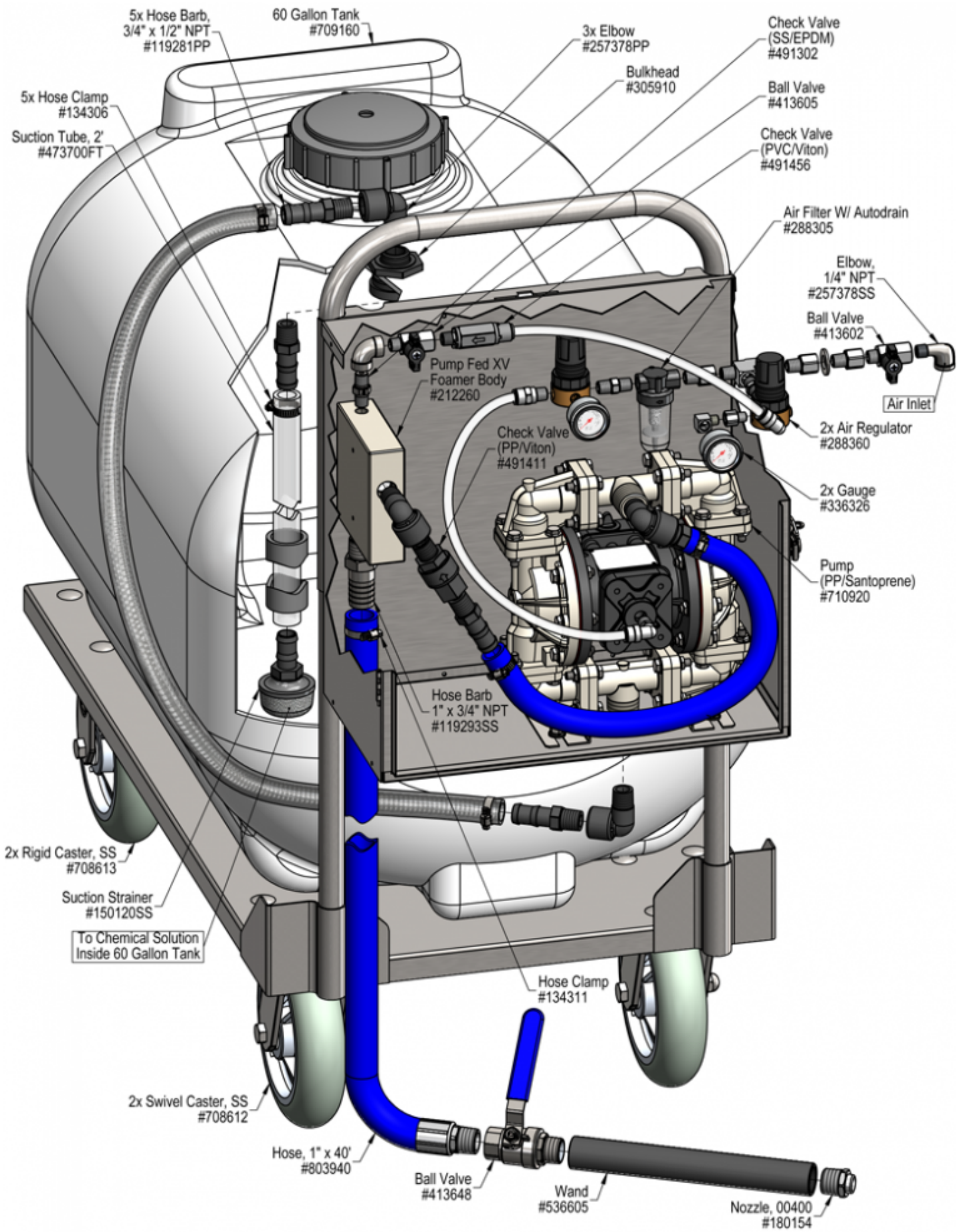

Troubleshooting Guide

AF 944186 • Portable 60 Gallon Freedom XV Foamer

Problem	Possible Cause / Solution	
	Startup	Maintenance
A) Air pump will not pump or runs with no output.	1, 2, 3, 4	8, 12
B) Foam surges and/or hose "bucks".	1, 2, 3, 4, 5, 6	
C) Foam output too wet.	1, 2, 3, 4, 5	8, 9, 11
D) Foam output too dry.	2	9, 11, 12
E) Cleaning results not acceptable.	5, 6, 7, 8	9

Possible Cause / Solution	
Startup	Maintenance
<p>1. Inlet ball valve partially closed or air pressure too low. <ul style="list-style-type: none"> ◦ Completely open air inlet ball valve. </p> <p>2. Foam consistency air pressure too high <ul style="list-style-type: none"> ◦ Adjust the air regulator slowly clockwise until foam stabilizes. </p> <p>3. Discharge ball valve not completely open or Discharge hose kinked <ul style="list-style-type: none"> ◦ Completely open the discharge ball valve / straighten hose </p> <p>4. Solution tube not completely immersed in chemical or container empty <ul style="list-style-type: none"> ◦ Immerse tube or replenish chemical. </p> <p>5. Dilution too weak <ul style="list-style-type: none"> ◦ Add more chemical to solution container. </p> <p>6. Improper chemical <ul style="list-style-type: none"> ◦ Ensure product is recommended for foaming and/or the application </p> <p>7. Soil has hardened on surface <ul style="list-style-type: none"> ◦ Always rinse foam before it dries. </p>	<p>8. Solution strainer blocked <ul style="list-style-type: none"> ◦ Clean or replace </p> <p>9. Air regulator failed <ul style="list-style-type: none"> ◦ Clean or replace </p> <p>10. Air or water check valve(s) failed <ul style="list-style-type: none"> ◦ Clean or replace </p> <p>11. Nozzle size too small or missing <ul style="list-style-type: none"> ◦ See REQUIREMENTS, page 1. </p> <p>12. Problem with air pump <ul style="list-style-type: none"> ◦ Refer to air pump instruction manual. Replace pump. </p>

PREVENTIVE MAINTENANCE: When the unit will be out of service for extended periods run water through the system to flush the chemical and help prevent chemical build-up.

